

# CERTPARK



## QUESTION & ANSWER



CERTPARK.COM

Accurate Study Guides,  
High Passing Rate!  
provides update  
free of charge  
in one year!



<https://www.certpark.com>

**Exam** : **200-101**

**Title** : Interconnecting Cisco  
Networking Devices Part 2

**Version** : DEMO

1.Refer to the exhibit.

```
Switch# show spanning-tree vlan 1
VLAN0001
  Spanning tree enabled protocol rstp
  Root ID    Priority    20481
            Address    0008.217a.5800
            Cost      38
            Port      1 (FastEthernet0/1)
            Hello Time 2 sec  Max Age 20 sec  Forward Delay 15 sec

  Bridge ID  Priority    32769 (priority 32768 sys-id-ext 1)
            Address    0008.205c.6600
            Hello Time 2 sec  Max Age 20 sec  Forward Delay 15 sec
            Aging Time 300

Interface          Role Sts Cost      Prio.Nbr Type
-----
Fa0/1              Root FWD 19        128.1   P2p
Fa0/4              Desg FWD 38        128.1   P2p
Fa0/11             Altn BLK 57        128.1   P2p
Fa0/13             Desg FWD 38        128.1   P2p
```

Why has this switch not been elected the root bridge for VLAN1?

- A. It has more than one interface that is connected to the root network segment.
- B. It is running RSTP while the elected root bridge is running 802.1d spanning tree.
- C. It has a higher MAC address than the elected root bridge.
- D. It has a higher bridge ID than the elected root bridge.

**Answer: D**

Explanation:[http://www.cisco.com/en/US/tech/tk389/tk621/technologies\\_tech\\_note09186a008009482f.shtml](http://www.cisco.com/en/US/tech/tk389/tk621/technologies_tech_note09186a008009482f.shtml) When a switch receives a BPDU, it first compares priority, the lower number wins. If a tie, compare MAC, the smaller one wins. Here Switch has 32769 priority which is greater than 20481 so switch will not elect for root bridge. It says the bridge priority for Switch is 32769, and the root priority is 20481. Which means that some other switch has the lower priority and won the election for VLAN 1.

2.Refer to the exhibit .

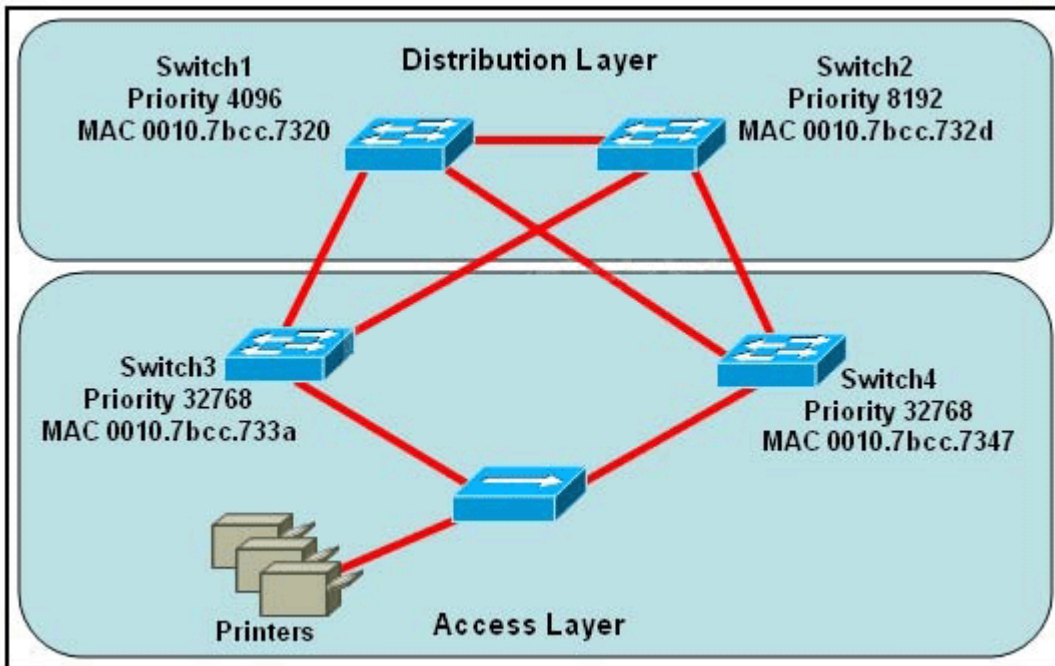

Which switch provides the spanning-tree designated port role for the network segment that services the printers?

- A. Switch1
- B. Switch2
- C. Switch3
- D. Switch4

**Answer:** C

Explanation: First, the question asks what switch services the printers, so it can be Switch 3 or Switch 4 which is connected directly to the Printers. Designated port is a port that is in the forwarding state. All ports of the root bridge are designated ports. Switch 3 and Switch 4 has same priority so it will see on lowest MAC address and here switch 3 has lowest MAC address. So switch 3 segment will play a Designated port role. By comparing the MAC address of Switch 3 and Switch 4 we found that the MAC of Switch 3 is smaller. Therefore the interface connected to the Printers of Switch 3 will become designated interface and the interface of Switch 4 will be blocked.

3.Refer to the exhibit.

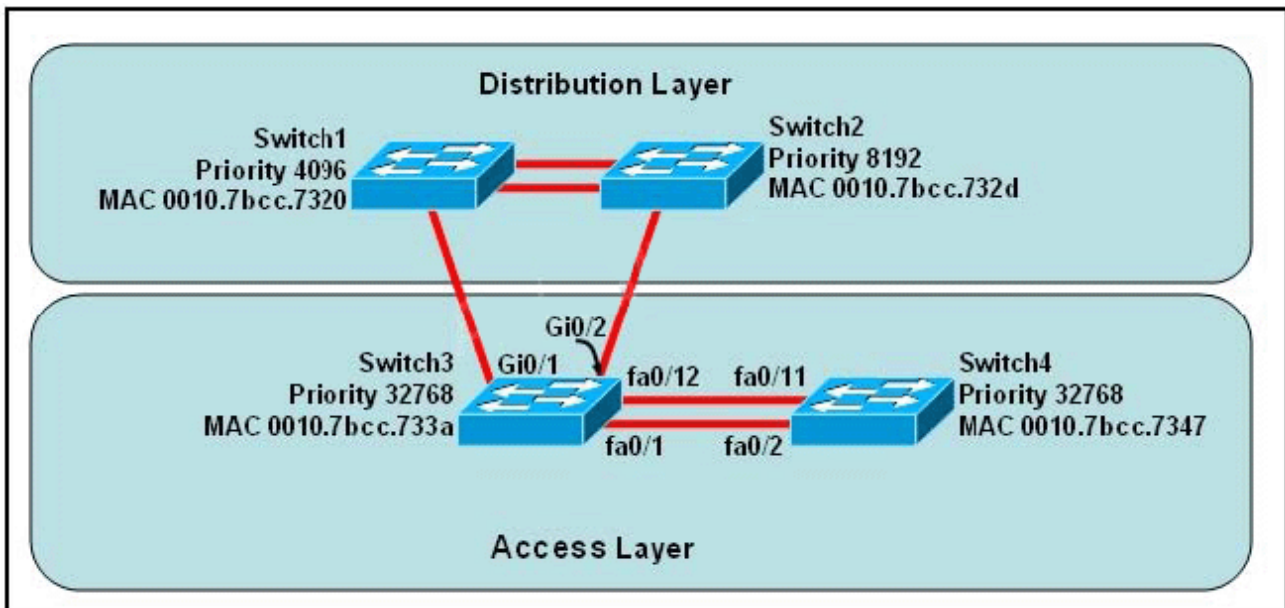

At the end of an RSTP election process, which access layer switch port will assume the discarding role?

- A. Switch3, port fa0/1
- B. Switch3, port fa0/12
- C. Switch4, port fa0/11
- D. Switch4, port fa0/2
- E. Switch3, port Gi0/1
- F. Switch3, port Gi0/2

**Answer: C**

Explanation: In this question, we only care about the Access Layer switches (Switch3 & 4). Switch 3 has a lower bridge ID than Switch 4 (because the MAC of Switch3 is smaller than that of Switch4) so both ports of Switch3 will be in forwarding state. The alternative port will surely belong to Switch4. Switch4 will need to block one of its ports to avoid a bridging loop between the two switches. But how does Switch4 select its blocked port? Well, the answer is based on the BPDUs it receives from Switch3. A BPDU is superior than another if it has:

1. A lower Root Bridge ID
2. A lower path cost to the Root
3. A lower Sending Bridge ID
4. A lower Sending Port ID

These four parameters are examined in order. In this specific case, all the BPDUs sent by Switch3 have the same Root Bridge ID, the same path cost to the Root and the same Sending Bridge ID. The only parameter left to select the best one is the Sending Port ID (Port ID = port priority + port index). In this case the port priorities are equal because they use the default value, so Switch4 will compare port index values, which are unique to each port on the switch, and because Fa0/12 is inferior to Fa0/1, Switch4 will select the port connected with Fa0/1 (of Switch3) as its root port and block the other port -> Port fa0/11 of Switch4 will be blocked (discarding role)

4.Refer to the exhibit.

```
Switch# show spanning-tree interface fastethernet 0/10
Vlan          Role Sts Cost      Prio.Mbr Type
-----
VLAN0001      Root FWD 19        128.1   P2p
VLAN0002      Altn BLK 19        128.2   P2p
VLAN0003      Root FWD 19        128.2   P2p
```

Given the output shown from this Cisco Catalyst 2950, what is the reason that interface FastEthernet 0/10 is not the root port for VLAN 2?

- A. This switch has more than one interface connected to the root network segment in VLAN 2.
- B. This switch is running RSTP while the elected designated switch is running 802.1d Spanning Tree.
- C. This switch interface has a higher path cost to the root bridge than another in the topology.
- D. This switch has a lower bridge ID for VLAN 2 than the elected designated switch.

**Answer: C**

Explanation: These four parameters are examined in order to make root bridge , root port , designated port. Other switch has lowest Sending Bridge ID or Sending Port ID so vlan 2 is not the root port.

1. A lower Root Bridge ID  
2. A lower path cost to the Root  
3. A lower Sending Bridge ID  
4. A lower Sending Port ID

5. Which two of these statements regarding RSTP are correct? (Choose two.)

- A. RSTP cannot operate with PVST+.
- B. RSTP defines new port roles.
- C. RSTP defines no new port states.
- D. RSTP is a proprietary implementation of IEEE 802.1D STP.
- E. RSTP is compatible with the original IEEE 802.1D STP.

**Answer: B,E**

Explanation: [http://www.cisco.com/en/US/tech/tk389/tk621/technologies\\_white\\_paper09186a0080094cfa.shtml](http://www.cisco.com/en/US/tech/tk389/tk621/technologies_white_paper09186a0080094cfa.shtml)

Port Roles The role is now a variable assigned to a given port. The root port and designated port roles remain, while the blocking port role is split into the backup and alternate port roles. The Spanning Tree Algorithm (STA) determines the role of a port based on Bridge Protocol Data Units (BPDUs). In order to simplify matters, the thing to remember about a BPDU is there is always a method to compare any two of them and decide whether one is more useful than the other. This is based on the value stored in the BPDU and occasionally on the port on which they are received. This considered, the information in this section explains practical approaches to port roles.

Compatibility with 802.1D RSTP is able to interoperate with legacy STP protocols. However, it is important to note that the inherent fast convergence benefits of 802.1w are lost when it interacts with legacy bridges.